

Model No: RX4-500

4 Channel Receiver : 500m Code Hopping

Technical Specifications:

Model:	RX4-500
Encryption type:	Code hopping
Transmission frequency:	403MHz (Local) 433MHz (Export)
Transmission method:	OOK
Modulation:	AM
Memory capacity per channel:	64 remotes
Transmission range:	500m "Line of sight"
Voltage range:	12VDC / 24VAC
Standby current consumption:	+/-22mA 10%
Current consumption all on:	+/-126mA 10%
Operating Temperature:	-3°C to 49°C
Dimension (lxbxh)	145 x 66 x 40mm
Gross weight:	135g
Software revision: Sept 2017	1 Long Beep 2 Short Beeps

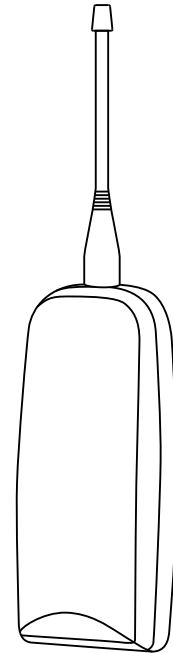

Features:

Code-Hopping Encryption
 4 Independent Relay outputs
 Normally Open / Closed
 Weather-proof ABS housing
 Frequency stability controlled +/- 75KHz

Approvals: *

This product is approved for use in residential, commercial and light Industrial environment and complies with the essential protection requirements of the R&TTE Directive 1999/EC on the approximation of the laws of the Member states relating to electromagnetic compatibility and radio spectrum.

Certifications:
 ETSI EN300 220-V2.4.1
 ETSI EN301-489-3 V1.4.1
 ETSI EN301-489-1 V1.9.2
 IEC 60950-1:2005 + A1:2009
 ICASA TA 2017/2237



Order Codes:

4 Channel Receiver : 500m Code-hopping	RX4-500
--	---------



RX4 - 500

Opening the unit

Remove the Aerial and make sure the screw on the bottom side is removed. Carefully lift the lid up from the back end and unclip the top.

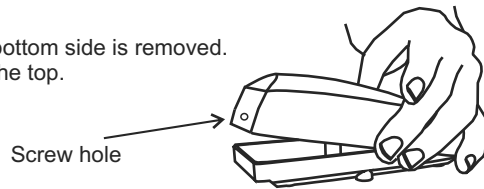

Mounting advice

The plastic housing is splash proof, and may be mounted externally if required. The unit should be mounted vertically for best performance. Ensure that you do not mount the unit close to electric fence cables or energizers, as these products produce extreme levels of interference and may reduce the performance of the product. If mounting indoors try and centralise the unit, and keep it at least 3 metres away from armed response company's alarm radio transmitters.

We recommend the unit to be mounted more than 3 metres above the floor height just above the trap door. For large properties that require exceptional range, mount the unit externally.

Always conduct a signal range test before you hand over the product to the client, ensuring that the system works reliably. You may need to move the unit if you encounter dead spots. In rare cases you may need to install a booster repeater unit for coverage around large multi levelled sites.

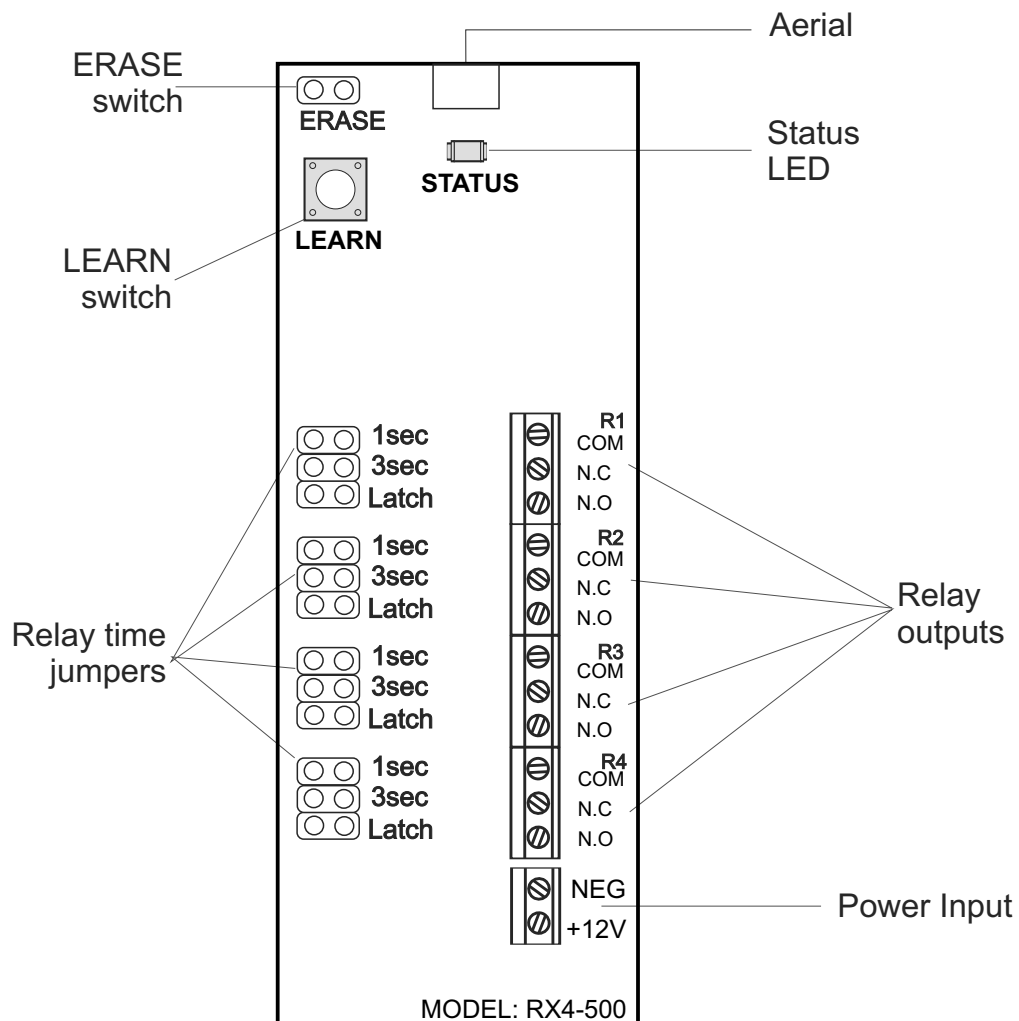
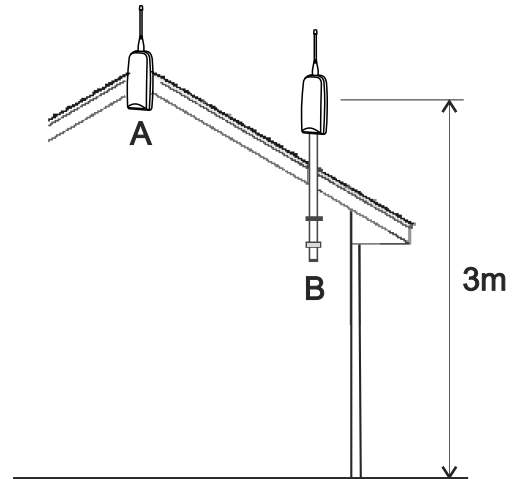

Wiring diagram

Typical gate motor wiring

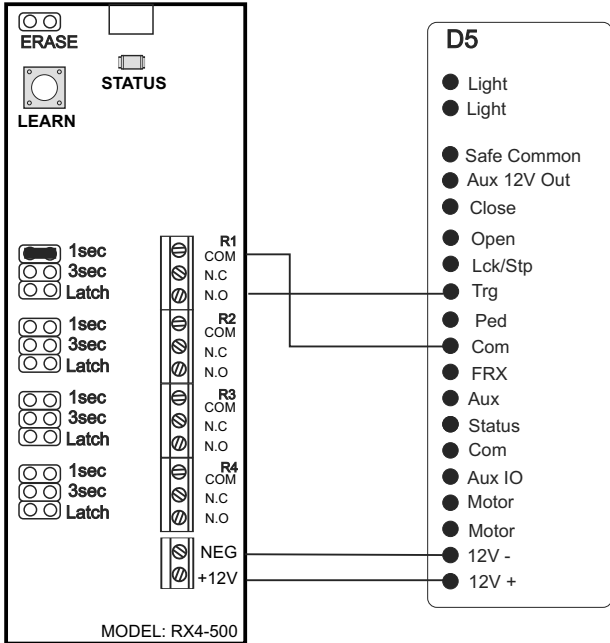

Typical mag lock

Set Jumper to 30 Seconds to release the maglock when the remote is activated

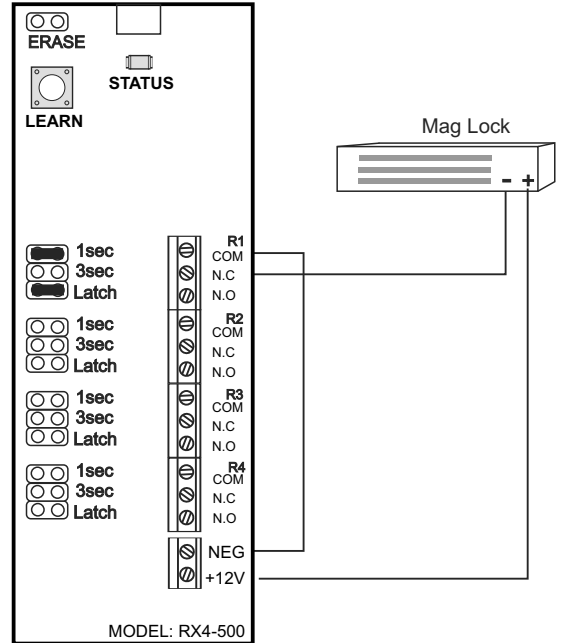

Typical alarm panel wiring

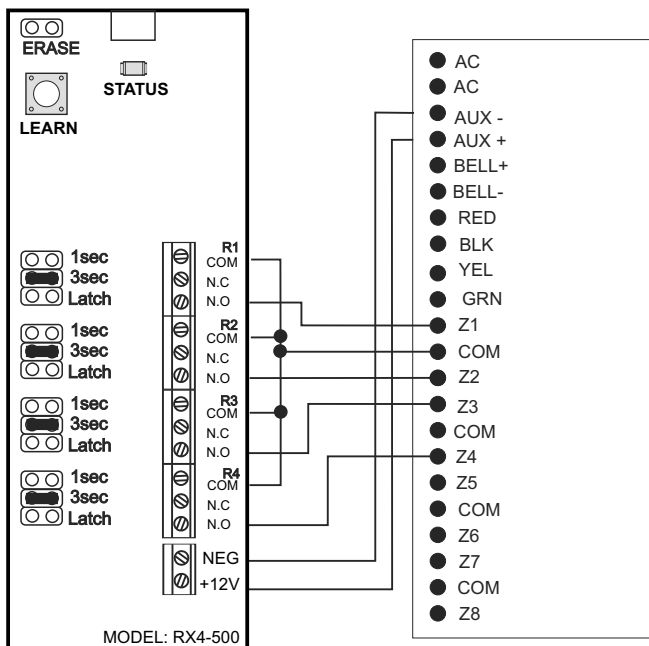

Typical alarm radio transmitter & a 3Min siren output for a simple Panic system

Note: Program the Panic remote into both Relay 1 & 2

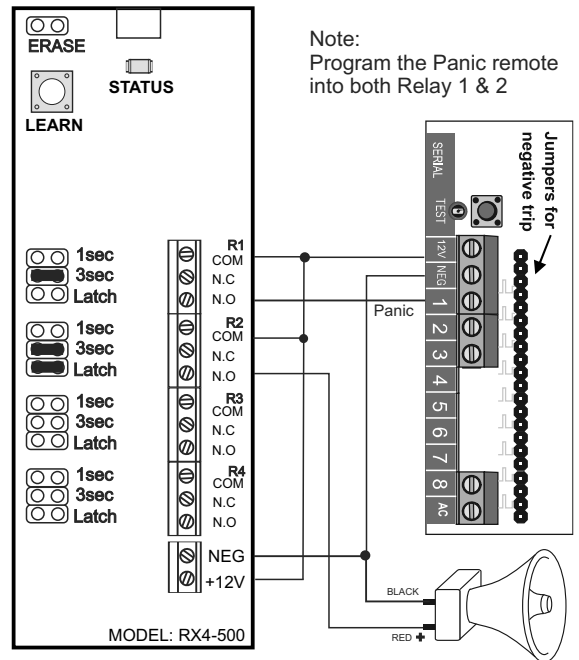

Defaulting the RX4-500

Note: Please default the unit first before installation. This will erase any previously programmed factory test remotes from the memory.

You can default a specific relay channel. Remove the jumpers off the relay time header for the respective channel you wish to default.



Remove all jumpers off the relay time headers



Press and hold for more than 10 Seconds. When the beeping stops the unit is defaulted. Wait a few seconds until it re-boots.

Programming remotes in

1. Default the unit before you begin a new installation. This erases all previously programmed remotes.
2. Press the LEARN switch once to step to relay 1. (1 x beep sounds)
3. Press the button on the remote control a few times to learn in to the RX4-500 (2x beeps sound)
4. Continue to learn in any additional remote controls until all the remotes are programmed in.
5. Press the LEARN switch again to step to relay 2. (1x beep sounds)
6. Repeat Step 3; 4 & 5 until all the remotes are programmed in to each respective relay.
7. Once Relay 4 is programmed, press the LEARN switch once more to step past relay 4 and exit out of learn mode. (1 x long beep sounds)

Note: The unit can be SET to "High Traffic Mode". This mode is recommended when PIRTX units are programmed into the receiver for Wireless Motion detectors. Please follow the HIGH TRAFFIC mode setup below:

Setup HIGH TRAFFIC mode

Set the unit to **HIGH TRAFFIC** mode if using the receiver for applications where more than 100 triggers will be received per day. We recommend setting High Traffic mode with Wireless PIRTX transmitters.

1. Remove Power to the unit and then PRESS and hold in the LEARN button.
2. Power up the unit while holding in the LEARN button, the unit will double beep ten times.
3. Once the units sound its BUZZER continuously it is ready. You can let go the LEARN button now.
4. The STATUS LED will flicker three times every second. (HIGH TRAFFIC MODE)

STATUS LED :- One Flash = STANDARD MODE

STATUS LED:- Three Flicks = HIGH TRAFFIC MODE

Erasing Individual Remotes

1. Link the ERASE jumper
2. Press the LEARN switch
3. Press the remote to be erased
4. Repeat step 2 & 3 for each remote to be erased
5. Remove ERASE jumper when done

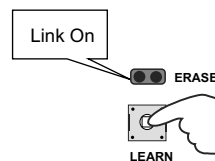

Repeat for each remote to be erased.

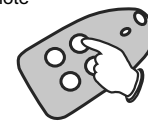

Press the button to be erased



20 beeps

You must erase one remote at a time.

Programming the ON/OFF function

1. Default the unit before you begin a new installation. This erases all previously programmed remotes.
2. Select the 1 sec & 3 sec relay time jumpers respectively.
3. Press the LEARN switch once to step to relay 1 (ON command) (1 x beep sounds)
4. Press the button on the remote control for the ON command. (2 x short beeps sound)
5. Press the LEARN switch again to advance to the OFF command. (2 x beep sounds)
6. Press the button on the remote control for the OFF command. (2 x short beeps sound)
7. Press the LEARN switch again to advance to the next relay channel.
8. Repeat Step 3 - 6 until all the remotes are programmed in to each respective relay.
7. Once Relay 4 is programmed, press the LEARN switch once more to step past relay 4 and exit out of learn mode. (1 x long beep sounds)

Relay time jumper settings

0.5 Second	1 Second	3 Seconds	1 Minute	30 Seconds	3 Minutes	On / Off	Latch & Unlatch
Gate & garage door automation	Gate & garage door automation	Panic	Beam bypass on alarm system	Maglock release	Siren output or beam bypass	Code 1 = ON Code 2 = OFF	Arming & Disarming alarm panels

Warranty

This product is sold subject to our standard warranty conditions and is warranted against defects in workmanship for a period of two years.

Customer Support line: +2711 462 5101 E-mail: technical@sherlotronics.co.za